

**FEATURES**

- BUS+SEQUENCER+FADER+DIMMER+DRIVER
- DC Input 12-24 Vdc
- Bus command: DMX512-A + RDM or DALI
- Local command: Stand alone function (Dip Switch settings)
- Control: RGB or RGBW Color
- Current outputs or voltage outputs for LED strip
- Typical efficiency > 95%
- Adjusting the brightness up to completed off
- Soft start and soft stop
- Optimized output curve
- Extended temperature range
- 100% Test functional – 2 Years warranty

**Constant current variants (common anode)**

Application (4 channels output): RGB+W

CODE	Supply Voltage	Output	Channels	Command	
DLX1224-4CC350-DMX	12+24V DC	4x350mA	4	DMX	EASY
DLX1224-4CC350-DALI	12+24V DC	4x350mA	4	DALI	EASY
DLX1224-4CC500-DMX	12+24V DC	4x500mA	4	DMX	EASY
DLX1224-4CC500-DALI	12+24V DC	4x500mA	4	DALI	EASY

**Constant voltage variants (common anode)**

Application (4 channels output): RGB+W

CODE	Supply Voltage	Output	Channels	Command	
DLX1224-4CV-DMX	12+24V DC	4 x 5A (max 10A tot.)	4	DMX	EASY
DLX1224-4CV-DALI	12+24V DC	4 x 5A (max 10A tot.)	4	DALI	EASY

**Protections**

OTP*	Over temperature protection
OVP	Over voltage protection
UVP	Under voltage protection
RVP	Reverse polarity protection
IFP	Internal circuit input fuse protection
SCP*	Short circuit protection
OCP*	Open circuit protection
CLP*	Current limit protection

\* these protections are added in "P" variant only

## Reference standards

EN 61347-1:2008 +A1:2011+A2:2013	Lamp controlgear - Part 1: General and safety requirements
EN 61000-3-2:2014	Electromagnetic compatibility (EMC) - Part 3-2: Limits - Limits for harmonic current emissions (equipment input current $\leq 16$ A per phase)
EN 61000-3-3:2013	Electromagnetic compatibility (EMC) - Part 3-3: Limits - Limitation of voltage changes, voltage fluctuations and flicker in public low-voltage supply systems, for equipment with rated current $\leq 16$ A per phase and not subject to conditional connection
EN 62384:2006+A1:2009	DC or AC supplied electronic control gear for LED modules - Performance requirements
EN 55015:2013+A1:2015	Limits and methods of measurement of radio disturbance characteristics of electrical lighting and similar equipment
EN 61547:2009	Equipment for general lighting purposes - EMC immunity requirements
EN 50581:2012	Technical documentation for the assessment of electrical and electronic products with respect to the restriction of hazardous substances
IEC/EN 62386-101	Digital addressable lighting interface - Part 101: General requirements - System
IEC/EN 62386-102	Digital addressable lighting interface - Part 102: General requirements - Control gear
IEC/EN 62386-207	Digital addressable lighting interface - Part 207: Particular requirements for control gear - LED modules (device type 6)
IEC 60929-E.2.1	Control interface for controllable ballasts - control by d.c. voltage - functional specification
ANSI E 1.3	Entertainment Technology - Lighting Control Systems - 0 to 10V Analog Control Specification
ANSI E1.11	Entertainment Technology - USITT DMX512-A - Asynchronous Serial Digital Data Transmission Standard for Controlling Lighting Equipment and Accessories
ANSI E1.20	Entertainment Technology-RDM-Remote Device Management over USITT DMX512 Networks
-	MODBUS APPLICATION PROTOCOL SPECIFICATION V1.1b

## Technical Specifications

	Variant			
	Constant current		Constant voltage	
	4 channels		4 channels	
Supply voltage	DC min: 10.8 Vdc .. max: 26.4 Vdc			
Input current	max 2 A		max 10A	
Output voltage	min: $V_{in}/4$	max: $V_{in}-0,9V$	= $V_{in}$	
Output current	350mA/ch	500mA/ch	max 5 A/ch <sup>1)</sup>	
	<b>max 1,4 A total</b>	<b>max 2 A total</b>	<b>max 10 A total<sup>1)</sup></b>	
Nominal power <sup>1)</sup>	@12V	16,8 W	24 W	120 W
	@24V	33,6 W	48 W	240 W
Thermal shutdown	150 °C		150 °C	
D-PWM dimming frequency	250Hz			
D-PWM resolution	16 bit			
D-PWM range	0,1 – 100 %			
Storage Temperature	min: -40 max: +60 °C			
Ambient Temperature <sup>1)</sup>	min: -10 max: +40 °C			
Protection grade	IP20			
Wiring	2.5mm <sup>2</sup> solid - 1.5mm <sup>2</sup> stranded - 30/12 AWG			
Mechanical dimensions	88 x 54 x 26 mm			
Packaging dimensions	106 x 59 x 36 mm			
Weight	74g			

<sup>1)</sup> maximum value, dependent on the ventilation conditions

## Installation

Connect the switching supply, connect the BUS (DALI or DMX+RDM), connect the leds.

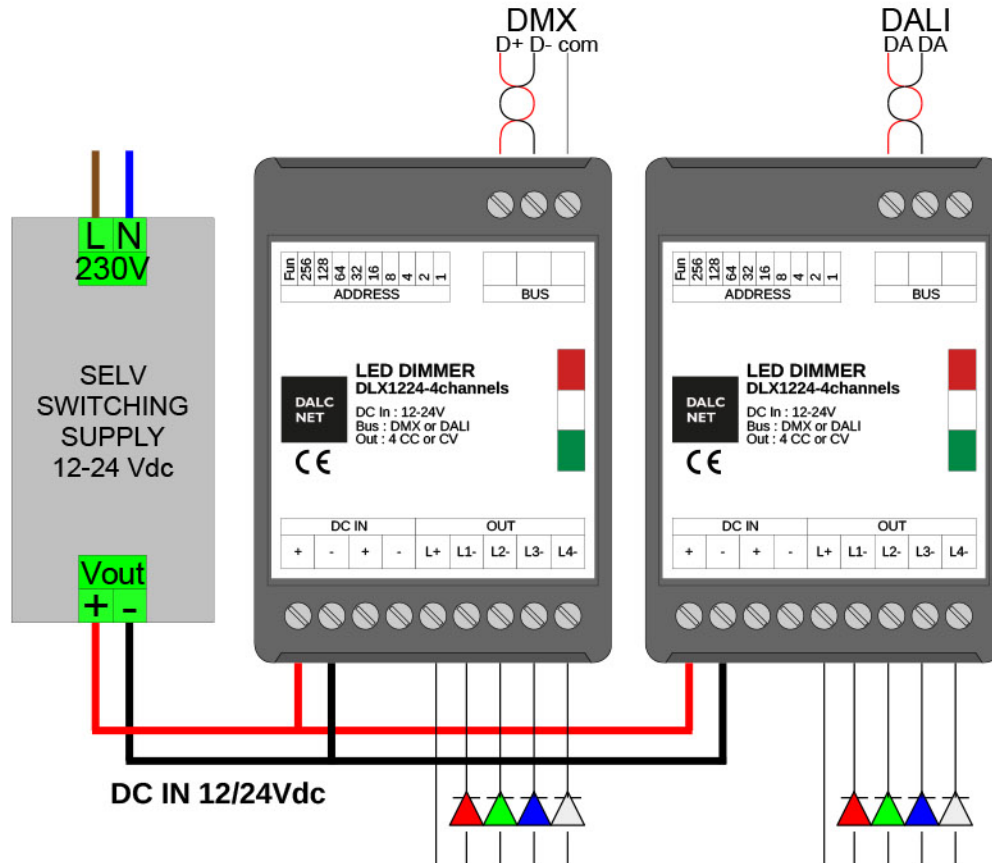

## Technical Notes:

### Installation:

- Installation and maintenance must be performed only by qualified personnel in compliance with current regulations.
- The product must be installed inside an electrical panel protected against overvoltages.
- The product must be installed in a vertical or horizontal position with the cover / label upwards or vertically; Other positions are not permitted. It is not permitted to bottom-up position (with the cover / label updown).
- Keep separated the circuits at 230V (LV) and the circuits not SELV from circuits to low voltage (SELV) and from any connection with this product. It is absolutely forbidden to connect, for any reason whatsoever, directly or indirectly, the 230V mains voltage to the bus or to other parts of the circuit.

### Power Supply:

- For the power supply use only a SELV power supplies with limited current, short circuit protection and the power must be dimensioned correctly.
- In case of using power supply with ground terminals, all points of the protective earth (PE = Protection Earth) must be connected to a valid and certified protection earth.
- The connection cables between the power source "low voltage" and the product must be dimensioned correctly and they should be isolated from every wiring or parts at voltage not SELV. Use double insulated cables.
- Dimension the power supply for the load connected to the device. If the power supply is oversized compared with the maximum absorbed current, insert a protection against over-current between the power supply and the device.
- For the constant current output, the voltage of LED module (Vf) must be less of 5V at the voltage of power supply.

### Command:

- The length and type of the connection cables at the BUS (DMX512, Modbus, DALI or other) use cables as per specification of the respective protocols and regulations and they should be isolated from every wiring or parts at voltage not SELV. Use double insulated shielded and twisted cables.
- All the product and the control signal connect at the bus (DMX512, Modbus, DALI or other) must be SELV (the devices connected must be SELV or supply a SELV signal)



### Outputs:

- The length of the connection cables between the product and the LED module must be less than 10m; the cables must be dimensioned correctly and they should be isolated from every wiring or parts at voltage not SELV. Is preferable to use shielded and twisted cables.

■ **STAND ALONE SETUP**

Leds are managed by the DIP-SWITCH of the device.

**Configuration**

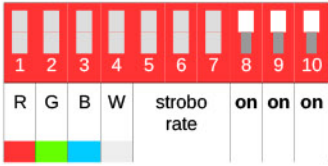
Function	DIP-SWITCH																																																																														
64 static colours		<p><b>DIP 9 = OFF      DIP 10 = ON</b></p> <p><i>To set the intensity levels:</i></p> <table border="1"> <thead> <tr> <th rowspan="2">LEVELS</th> <th colspan="2">1<sup>st</sup> CHANNEL</th> <th colspan="2">2<sup>nd</sup> CHANNEL</th> <th colspan="2">3<sup>rd</sup> CHANNEL</th> <th colspan="2">4<sup>th</sup> CHANNEL</th> </tr> <tr> <th>DIP 1</th> <th>DIP 2</th> <th>DIP 3</th> <th>DIP 4</th> <th>DIP 5</th> <th>DIP 6</th> <th>DIP 7</th> <th>DIP 8</th> </tr> </thead> <tbody> <tr> <td>100%</td> <td>ON</td> <td>ON</td> <td>ON</td> <td>ON</td> <td>ON</td> <td>ON</td> <td>ON</td> <td>ON</td> </tr> <tr> <td>66%</td> <td>OFF</td> <td>ON</td> <td>OFF</td> <td>ON</td> <td>OFF</td> <td>ON</td> <td>OFF</td> <td>ON</td> </tr> <tr> <td>33%</td> <td>ON</td> <td>OFF</td> <td>ON</td> <td>OFF</td> <td>ON</td> <td>OFF</td> <td>ON</td> <td>OFF</td> </tr> <tr> <td>0%</td> <td>OFF</td> <td>OFF</td> <td>OFF</td> <td>OFF</td> <td>OFF</td> <td>OFF</td> <td>OFF</td> <td>OFF</td> </tr> </tbody> </table>	LEVELS	1 <sup>st</sup> CHANNEL		2 <sup>nd</sup> CHANNEL		3 <sup>rd</sup> CHANNEL		4 <sup>th</sup> CHANNEL		DIP 1	DIP 2	DIP 3	DIP 4	DIP 5	DIP 6	DIP 7	DIP 8	100%	ON	ON	ON	ON	ON	ON	ON	ON	66%	OFF	ON	OFF	ON	OFF	ON	OFF	ON	33%	ON	OFF	ON	OFF	ON	OFF	ON	OFF	0%	OFF	OFF	OFF	OFF	OFF	OFF	OFF	OFF																								
LEVELS	1 <sup>st</sup> CHANNEL			2 <sup>nd</sup> CHANNEL		3 <sup>rd</sup> CHANNEL		4 <sup>th</sup> CHANNEL																																																																							
	DIP 1	DIP 2	DIP 3	DIP 4	DIP 5	DIP 6	DIP 7	DIP 8																																																																							
100%	ON	ON	ON	ON	ON	ON	ON	ON																																																																							
66%	OFF	ON	OFF	ON	OFF	ON	OFF	ON																																																																							
33%	ON	OFF	ON	OFF	ON	OFF	ON	OFF																																																																							
0%	OFF	OFF	OFF	OFF	OFF	OFF	OFF	OFF																																																																							
Rainbow		<p><b>DIP 8 = OFF      DIP 9 = ON      DIP 10 = ON</b></p> <p><i>To set the intensity levels:</i></p> <table border="1"> <thead> <tr> <th rowspan="2">LEVELS</th> <th colspan="3">COLOURS</th> <th colspan="3">WHITE</th> </tr> <tr> <th>DIP 1</th> <th>DIP 2</th> <th>DIP 3</th> <th colspan="3">DIP 4</th> </tr> </thead> <tbody> <tr> <td>100%</td> <td>ON</td> <td>ON</td> <td>ON</td> <td colspan="3">ON</td> </tr> <tr> <td>66%</td> <td>OFF</td> <td>ON</td> <td>OFF</td> <td colspan="3">ON</td> </tr> <tr> <td>33%</td> <td>ON</td> <td>OFF</td> <td>ON</td> <td colspan="3">OFF</td> </tr> <tr> <td>0%</td> <td>OFF</td> <td>OFF</td> <td>OFF</td> <td colspan="3">OFF</td> </tr> </tbody> </table> <p><i>To set the time between two adjacent colour changes:</i></p> <table border="1"> <thead> <tr> <th>TIME</th> <th>DIP 5</th> <th>DIP 6</th> <th>DIP 7</th> </tr> </thead> <tbody> <tr> <td>30 min.</td> <td>-----ON-----</td> <td>-----ON-----</td> <td>-----ON-----</td> </tr> <tr> <td>15 min.</td> <td>-----OFF-----</td> <td>-----ON-----</td> <td>-----ON-----</td> </tr> <tr> <td>6 min.</td> <td>----ON----</td> <td>----OFF----</td> <td>----ON----</td> </tr> <tr> <td>1 min.</td> <td>---OFF---</td> <td>---OFF---</td> <td>---ON---</td> </tr> <tr> <td>30 sec.</td> <td>--ON--</td> <td>--ON--</td> <td>--OFF--</td> </tr> <tr> <td>15 sec.</td> <td>-OFF-</td> <td>-ON-</td> <td>-OFF-</td> </tr> <tr> <td>6 sec.</td> <td>-ON-</td> <td>-OFF-</td> <td>-OFF-</td> </tr> <tr> <td>3 sec.</td> <td>OFF</td> <td>OFF</td> <td>OFF</td> </tr> </tbody> </table>	LEVELS	COLOURS			WHITE			DIP 1	DIP 2	DIP 3	DIP 4			100%	ON	ON	ON	ON			66%	OFF	ON	OFF	ON			33%	ON	OFF	ON	OFF			0%	OFF	OFF	OFF	OFF			TIME	DIP 5	DIP 6	DIP 7	30 min.	-----ON-----	-----ON-----	-----ON-----	15 min.	-----OFF-----	-----ON-----	-----ON-----	6 min.	----ON----	----OFF----	----ON----	1 min.	---OFF---	---OFF---	---ON---	30 sec.	--ON--	--ON--	--OFF--	15 sec.	-OFF-	-ON-	-OFF-	6 sec.	-ON-	-OFF-	-OFF-	3 sec.	OFF	OFF	OFF
LEVELS	COLOURS			WHITE																																																																											
	DIP 1	DIP 2	DIP 3	DIP 4																																																																											
100%	ON	ON	ON	ON																																																																											
66%	OFF	ON	OFF	ON																																																																											
33%	ON	OFF	ON	OFF																																																																											
0%	OFF	OFF	OFF	OFF																																																																											
TIME	DIP 5	DIP 6	DIP 7																																																																												
30 min.	-----ON-----	-----ON-----	-----ON-----																																																																												
15 min.	-----OFF-----	-----ON-----	-----ON-----																																																																												
6 min.	----ON----	----OFF----	----ON----																																																																												
1 min.	---OFF---	---OFF---	---ON---																																																																												
30 sec.	--ON--	--ON--	--OFF--																																																																												
15 sec.	-OFF-	-ON-	-OFF-																																																																												
6 sec.	-ON-	-OFF-	-OFF-																																																																												
3 sec.	OFF	OFF	OFF																																																																												
Strobo		<p><b>DIP 8 = ON      DIP 9 = ON      DIP 10 = ON</b></p> <p><i>To turn on the outputs:</i></p> <table border="1"> <thead> <tr> <th rowspan="2">LEVEL</th> <th>1<sup>st</sup> CHANNEL</th> <th>2<sup>nd</sup> CHANNEL</th> <th>3<sup>rd</sup> CHANNEL</th> <th>4<sup>th</sup> CHANNEL</th> </tr> <tr> <th>DIP 1</th> <th>DIP 2</th> <th>DIP 3</th> <th>DIP 4</th> </tr> </thead> <tbody> <tr> <td>100%</td> <td>ON</td> <td>ON</td> <td>ON</td> <td>ON</td> </tr> <tr> <td>0%</td> <td>OFF</td> <td>OFF</td> <td>OFF</td> <td>OFF</td> </tr> </tbody> </table> <p><i>To set the strobo frequency:</i></p> <table border="1"> <thead> <tr> <th>fps</th> <th>DIP 5</th> <th>DIP 6</th> <th>DIP 7</th> </tr> </thead> <tbody> <tr> <td>10</td> <td>ON</td> <td>ON</td> <td>ON</td> </tr> <tr> <td>8</td> <td>OFF</td> <td>ON</td> <td>ON</td> </tr> <tr> <td>6</td> <td>ON</td> <td>OFF</td> <td>ON</td> </tr> <tr> <td>5</td> <td>OFF</td> <td>OFF</td> <td>ON</td> </tr> <tr> <td>4</td> <td>ON</td> <td>ON</td> <td>OFF</td> </tr> <tr> <td>3</td> <td>OFF</td> <td>ON</td> <td>OFF</td> </tr> <tr> <td>2</td> <td>ON</td> <td>OFF</td> <td>OFF</td> </tr> <tr> <td>1</td> <td>OFF</td> <td>OFF</td> <td>OFF</td> </tr> </tbody> </table>	LEVEL	1 <sup>st</sup> CHANNEL	2 <sup>nd</sup> CHANNEL	3 <sup>rd</sup> CHANNEL	4 <sup>th</sup> CHANNEL	DIP 1	DIP 2	DIP 3	DIP 4	100%	ON	ON	ON	ON	0%	OFF	OFF	OFF	OFF	fps	DIP 5	DIP 6	DIP 7	10	ON	ON	ON	8	OFF	ON	ON	6	ON	OFF	ON	5	OFF	OFF	ON	4	ON	ON	OFF	3	OFF	ON	OFF	2	ON	OFF	OFF	1	OFF	OFF	OFF																						
LEVEL	1 <sup>st</sup> CHANNEL	2 <sup>nd</sup> CHANNEL		3 <sup>rd</sup> CHANNEL	4 <sup>th</sup> CHANNEL																																																																										
	DIP 1	DIP 2	DIP 3	DIP 4																																																																											
100%	ON	ON	ON	ON																																																																											
0%	OFF	OFF	OFF	OFF																																																																											
fps	DIP 5	DIP 6	DIP 7																																																																												
10	ON	ON	ON																																																																												
8	OFF	ON	ON																																																																												
6	ON	OFF	ON																																																																												
5	OFF	OFF	ON																																																																												
4	ON	ON	OFF																																																																												
3	OFF	ON	OFF																																																																												
2	ON	OFF	OFF																																																																												
1	OFF	OFF	OFF																																																																												

## ■ BUS DALI SETUP

Leds are managed by a DALI controller.

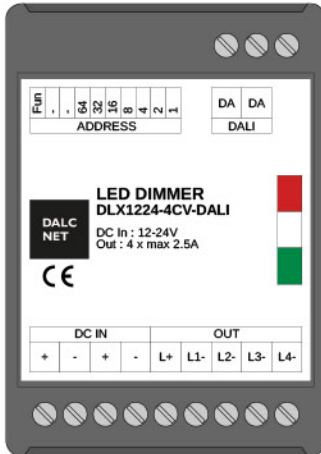

### Features

- DALI BUS

### DALI protocol reference standards

IEC/EN 62386-101	Digital addressable lighting interface - Part 101: General requirements - System
IEC/EN 62386-102	Digital addressable lighting interface - Part 102: General requirements - Control gear
IEC/EN 62386-207	Digital addressable lighting interface - Part 207: Particular requirements for control gear - LED modules (device type 6)

## Configuration

### ADDRESSING

By selectors	V
Random Address Allocation	V





DEFAULT VALUES

	FACTORY	RESET
ACTUAL LEVEL	254	254
POWER ON LEVEL	254	254
SYSTEM FAILURE LEVEL	254	254
MIN LEVEL	1	1
MAX LEVEL	254	254
FADE RATE	7	7
FADE TIME	0	0
SHORT ADDRESS	FF	(no change)
SEARCH ADDRESS	FF FF FF	FF FF FF
RANDOM ADDRESS	FF FF FF	FF FF FF
GROUP 0-7	0	0
GROUP 8-15	0	0
SCENE 0-15	MASK	MASK
STATUS INFORMATION	1??0????	0?100???
VERSION NUMBER	1	(no change)
PHYSICAL MIN. LEVEL	1	(no change)



## BUS DMX+RDM SETUP

LEDS are managed by a DMX controller.

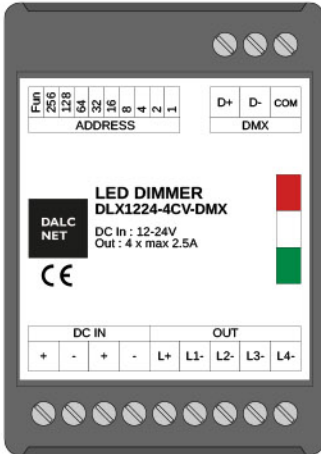

### Features

- BUS DMX512 (NSC+SIP+RDM)

### DMX protocol reference standards

ANSI E1.11	Entertainment Technology - USITT DMX512-A - Asynchronous Serial Digital Data Transmission Standard for Controlling Lighting Equipment and Accessories
ANSI E1.20	Entertainment Technology-RDM-Remote Device Management over USITT DMX512 Networks

### Technical Specification



Standard DMX512/RDM



### Configuration

#### ADDRESSING

By selectors	<input checked="" type="checkbox"/>
From RDM	<input checked="" type="checkbox"/>

Function	DIP-SWITCH																																									
DMX512		Addressing managed by RDM. <b>All DIPS are OFF.</b>																																								
Addressing managed by RDM	<table border="1"> <tr> <td>1</td><td>2</td><td>3</td><td>4</td><td>5</td><td>6</td><td>7</td><td>8</td><td>9</td><td>10</td> </tr> <tr> <td>off</td><td>off</td><td>off</td><td>off</td><td>off</td><td>off</td><td>off</td><td>off</td><td>off</td><td>off</td> </tr> </table>	1	2	3	4	5	6	7	8	9	10	off	off	off	off	off	off	off	off	off	off	<table border="1"> <tr> <td>DIP 1</td><td>DIP 2</td><td>DIP 3</td><td>DIP 4</td><td>DIP 5</td><td>DIP 6</td><td>DIP 7</td><td>DIP 8</td><td>DIP 9</td><td>DIP 10</td> </tr> <tr> <td>OFF</td><td>OFF</td><td>OFF</td><td>OFF</td><td>OFF</td><td>OFF</td><td>OFF</td><td>OFF</td><td>OFF</td><td>OFF</td> </tr> </table>	DIP 1	DIP 2	DIP 3	DIP 4	DIP 5	DIP 6	DIP 7	DIP 8	DIP 9	DIP 10	OFF	OFF	OFF	OFF	OFF	OFF	OFF	OFF	OFF	OFF
1	2	3	4	5	6	7	8	9	10																																	
off	off	off	off	off	off	off	off	off	off																																	
DIP 1	DIP 2	DIP 3	DIP 4	DIP 5	DIP 6	DIP 7	DIP 8	DIP 9	DIP 10																																	
OFF	OFF	OFF	OFF	OFF	OFF	OFF	OFF	OFF	OFF																																	
DMX512 Manual Addressing [1..511]		Manual Addressing																																								
	<table border="1"> <tr> <td>1</td><td>2</td><td>4</td><td>8</td><td>16</td><td>32</td><td>64</td><td>128</td><td>256</td><td>off</td> </tr> </table>	1	2	4	8	16	32	64	128	256	off	<p><b>DIP 10 = OFF</b></p> <p>DMX address from 1 to 511 = (1*dip1 + 2*dip2 + 4*dip3 + ... + 256*dip9)</p> <p>See the following table to set the address. In the table: - value 1 corresponds to dip ON - value 0 corresponds to dip OFF</p>																														
1	2	4	8	16	32	64	128	256	off																																	

addr	dip-switch	addr	dip-switch	addr	dip-switch	addr	dip-switch	addr	dip-switch	addr	dip-switch	addr	dip-switch	addr	dip-switch
	123456789		123456789		123456789		123456789		123456789		123456789		123456789		123456789
RDM	00000000	64	000000100	128	000000010	192	000000110	256	000000001	320	000000101	384	000000011	448	000000111
1	100000000	65	100000100	129	100000010	193	100000110	257	100000001	321	100000101	385	100000011	449	100000111
2	010000000	66	010000100	130	010000010	194	010000110	258	010000001	322	010000101	386	010000011	450	010000111
3	110000000	67	110000100	131	110000010	195	110000110	259	110000001	323	110000101	387	110000011	451	110000111
4	001000000	68	001000100	132	001000010	196	001000110	260	001000001	324	001000101	388	001000011	452	001000111
5	101000000	69	101000100	133	101000010	197	101000110	261	101000001	325	101000101	389	101000011	453	101000111
6	011000000	70	011000100	134	011000010	198	011000110	262	011000001	326	011000101	390	011000011	454	011000111
7	111000000	71	111000100	135	111000010	199	111000110	263	111000001	327	111000101	391	111000011	455	111000111
8	000100000	72	000100100	136	000100010	200	000100110	264	000100001	328	000100101	392	000100011	456	000100111
9	100100000	73	100100100	137	100100010	201	100100110	265	100100001	329	100100101	393	100100011	457	100100111
10	010100000	74	010100100	138	010100010	202	010100110	266	010100001	330	010100101	394	010100011	458	010100111
11	110100000	75	110100100	139	110100010	203	110100110	267	110100001	331	110100101	395	110100011	459	110100111
12	001100000	76	001100100	140	001100010	204	001100110	268	001100001	332	001100101	396	001100011	460	001100111
13	101100000	77	101100100	141	101100010	205	101100110	269	101100001	333	101100101	397	101100011	461	101100111
14	011100000	78	011100100	142	011100010	206	011100110	270	011100001	334	011100101	398	011100011	462	011100111
15	111100000	79	111100100	143	111100010	207	111100110	271	111100001	335	111100101	399	111100011	463	111100111
16	000010000	80	000010100	144	000010010	208	000010110	272	000010001	336	000010101	400	000010011	464	000010111
17	100010000	81	100010100	145	100010010	209	100010110	273	100010001	337	100010101	401	100010011	465	100010111
18	010010000	82	010010100	146	010010010	210	010010110	274	010010001	338	010010101	402	010010011	466	010010111
19	110010000	83	110010100	147	110010010	211	110010110	275	110010001	339	110010101	403	110010011	467	110010111
20	001010000	84	001010100	148	001010010	212	001010110	276	001010001	340	001010101	404	001010011	468	001010111
21	101010000	85	101010100	149	101010010	213	101010110	277	101010001	341	101010101	405	101010011	469	101010111
22	011010000	86	011010100	150	011010010	214	011010110	278	011010001	342	011010101	406	011010011	470	011010111
23	111010000	87	111010100	151	111010010	215	111010110	279	111010001	343	111010101	407	111010011	471	111010111
24	000110000	88	000110100	152	000110010	216	000110110	280	000110001	344	000110101	408	000110011	472	000110111
25	100110000	89	100110100	153	100110010	217	100110110	281	100110001	345	100110101	409	100110011	473	100110111
26	010110000	90	010110100	154	010110010	218	010110110	282	010110001	346	010110101	410	010110011	474	010110111
27	110110000	91	110110100	155	110110010	219	110110110	283	110110001	347	110110101	411	110110011	475	110110111
28	001110000	92	001110100	156	001110010	220	001110110	284	001110001	348	001110101	412	001110011	476	001110111
29	101110000	93	101110100	157	101110010	221	101110110	285	101110001	349	101110101	413	101110011	477	101110111
30	011110000	94	011110100	158	011110010	222	011110110	286	011110001	350	011110101	414	011110011	478	011110111
31	111110000	95	111110100	159	111110010	223	111110110	287	111110001	351	111110101	415	111110011	479	111110111
32	000001000	96	000001100	160	000001010	224	000001110	288	000001001	352	000001101	416	000001011	480	000001111
33	100001000	97	100001100	161	100001010	225	100001110	289	100001001	353	100001101	417	100001011	481	100001111
34	010001000	98	010001100	162	010001010	226	010001110	290	010001001	354	010001101	418	010001011	482	010001111
35	110001000	99	110001100	163	110001010	227	110001110	291	110001001	355	110001101	419	110001011	483	110001111
36	001001000	100	001001100	164	001001010	228	001001110	292	001001001	356	001001101	420	001001011	484	001001111
37	101001000	101	101001100	165	101001010	229	101001110	293	101001001	357	101001101	421	101001011	485	101001111
38	011001000	102	011001100	166	011001010	230	011001110	294	011001001	358	011001101	422	011001011	486	011001111
39	111001000	103	111001100	167	111001010	231	111001110	295	111001001	359	111001101	423	111001011	487	111001111
40	000101000	104	000101100	168	000101010	232	000101110	296	000101001	360	000101101	424	000101011	488	000101111
41	100101000	105	100101100	169	100101010	233	100101110	297	100101001	361	100101101	425	100101011	489	100101111
42	010101000	106	010101100	170	010101010	234	010101110	298	010101001	362	010101101	426	010101011	490	010101111
43	110101000	107	110101100	171	110101010	235	110101110	299	110101001	363	110101101	427	110101011	491	110101111
44	001101000	108	001101100	172	001101010	236	001101110	300	001101001	364	001101101	428	001101011	492	001101111
45	101101000	109	101101100	173	101101010	237	101101110	301	101101001	365	101101101	429	101101011	493	101101111
46	011101000	110	011101100	174	011101010	238	011101110	302	011101001	366	011101101	430	011101011	494	011101111
47	111101000	111	111101100	175	111101010	239	111101110	303	111101001	367	111101101	431	111101011	495	111101111
48	000011000	112	000011100	176	000011010	240	000011110	304	000011001	368	000011101	432	000011011	496	000011111
49	100011000	113	100011100	177	100011010	241	100011110	305	100011001	369	100011101	433	100011011	497	100011111
50	010011000	114	010011100	178	010011010	242	010011110	306	010011001	370	010011101	434	010011011	498	010011111
51	110011000	115	110011100	179	110011010	243	110011110	307	110011001	371	110011101	435	110011011	499	110011111
52	001011000	116	001011100	180	001011010	244	001011110	308	001011001	372	001011101	436	001011011	500	001011111
53	101011000	117	101011100	181	101011010	245	101011110	309	101011001	373	101011101	437	101011011	501	101011111
54	011011000	118	011011100	182	011011010	246	011011110	310	011011001	374	011011101	438	011011011	502	011011111
55	111011000	119	111011100	183	111011010	247	111011110	311	111011001	375	111011101	439	111011011	503	111011111
56	000111000	120	000111100	184	000111010	248	000111110	312	000111001	376	000111101	440	000111011	504	000111111
57	100111000	121	100111100	185	100111010	249	100111110	313	100111001	377	100111101	441	100111011	505	100111111
58	010111000	122	010111100	186	010111010	250	010111110	314	010111001	378	010111101	442	010111011	506	010111111
59	110111000	123	110111100	187	110111010	251	110111110	315	110111001	379	110111101	443	110111011	507	110111111
60	001111000	124	001111100	188	001111010	252	001111110	316	001111001	380	001111101	444	001111011	508	001111111
61	101111000	125	101111100	189	101111010	253	101111110	317	101111001	381	101111101	445	101111011	509	101111111
62	011111000	126	011111100	190	011111010	254	011111110	318	011111001	382	011111101	446	011111011	510	011111111
63	111111000	127	111111100	191	111111010	255	111111110	319	111111001	383	111111101	447	111111011	511	111111111

**APPLICATION EXAMPLE:** suppose you want to set the address 310 in the device. The following values need to be set on the switches:

DIP 1 = OFF, DIP 2 = ON, DIP 3 = ON, DIP 4 = OFF, DIP 5 = ON, DIP 6 = ON, DIP 7 = OFF, DIP 8 = OFF, DIP 9 = ON, DIP 10 = OFF

## Functions

Considering the colours configuration depicted in paragraph **Installation** at page 3, the 4 intensities can be controlled by the following slots:

Slot	Function	Value
1	R	R 0 .. 255
2	G	G 0 .. 255
3	B	B 0 .. 255
4	W	W 0.. 255

**APPLICATION EXAMPLE:** suppose you have manually set the address 310 on the device by selectors. Then, operating on DMX address:

- 310 (1<sup>st</sup> slot) first output intensity can be managed (red colour);
- 311 (2<sup>nd</sup> slot) second output intensity can be managed (green colour);
- 312 (3<sup>rd</sup> slot) third output intensity can be managed (blue colour);
- 313 (4<sup>th</sup> slot) fourth output intensity can be managed (white colour).

## RDM COMMANDS

REQUESTED PARAMETERS	
DISC_UNIQUE_BRANCH	V
DISC_MUTE	V
DISC_UN_MUTE	V
SUPPORTED_PARAMETERS	V
PARAMETER_DESCRIPTION	V
DEVICE_INFO	V
SOFTWARE_VERSION_LABEL	V
DMX_START_ADDRESS	V
IDENTIFY_DEVICE	V

SUPPORTED PARAMETERS	
PRODUCT_DETAIL_ID_LIST	V
DEVICE_MODEL_DESCRIPTION	V
MANUFACTURER_LABEL	V
DEVICE_LABEL	V
BOOT_SOFTWARE_VERSION_ID	V
BOOT_SOFTWARE_VERSION_LABEL	V
DMX_PERSONALITY	V
DMX_PERSONALITY_DESCRIPTION	V
SLOT_INFO	V
SLOT_DESCRIPTION	V
DEFAULT_SLOT_VALUE	V